







# **ProYard**

**6 cu.ft | 6 pieds cubic**  
**Wheelbarrow - PU Flat-Free Tire**  
**Brouette - Pneu Incevable en PU**

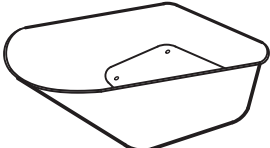

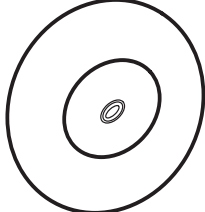

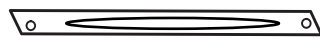
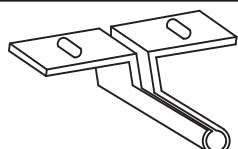
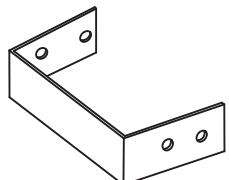
**190986**

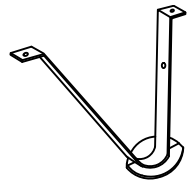

## PARTS LIST | LISTE DES PIÈCES

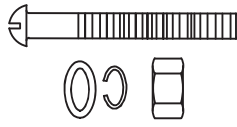
KEY CLÉ	PART PARTIE	DESCRIPTION	QTY QTÉ	KEY CLÉ	PART PARTIE	DESCRIPTION	QTY QTÉ
A		Tray Plateau	1	F		Plastic Wedge Cale en Plastique	2
B		Wheel Roue	1	G		Handle Poignée	2
				H		Axle Essieu	1
C		Leg Brace Attelle Jambière	1	I		Axle Bracket Support d'essieu	2
D		Nose Guard Garde nez	1	J		Leg support Support de jambe	2
E		Leg Jambe	2				

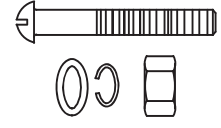
## HARDWARE LIST | LISTE DE MATÉRIEL

K		M8 X 135mm Bolt   Boulon	2	M		M8 X 70mm Bolt   Boulon	4
				N		M 8 x 50mm Bolt   Boulon	4
L		M8 X 80mm Bolt   Boulon	2	O		M8 X 20mm Bolt   Boulon	4

**Congratulations!**

You have bought one of TOOLWAY's fine line of quality products. Now let's see if you can pass the wheelbarrow assembly test. You should be able to do this in 30 minutes or less.

Before you begin, you will need to:

- Read instructions carefully.
- Place tray upside down on a flat level surface
- Gather necessary tools.
- Check bolt fitting against drawings provided on page 2.
- Ensure that you have all necessary parts from parts carton.

**Félicitations**

Vous avez acheté une item de la ligne fine de produits de qualité de TOOLWAY. Maintenant on vas voir si vous pouvez passer le test d'assemblage brouette. Vous devriez être capable de le faire en 30 minutes ou moins.

Avant de commencer, vous devez:

- Lire attentivement les instructions
- Placer le plateau à l'envers sur une surface plane et de niveau
- Rassembler les outils nécessaires
- Vérifier le boulon contre les dessins fournis à la page 2
- Assurez-vous que vous avez toutes les pièces nécessaires de carton de pièces



**ASSEMBLY INSTRUCTIONS | INSTRUCTIONS DE MONTAGE**

**NOTE: Do not completely tighten screws until assembly has been completed.**  
**Remarque: ne serrez pas complètement les vis avant que l'assemblage soit terminé**

**STEP/ ÉTAPE 1**

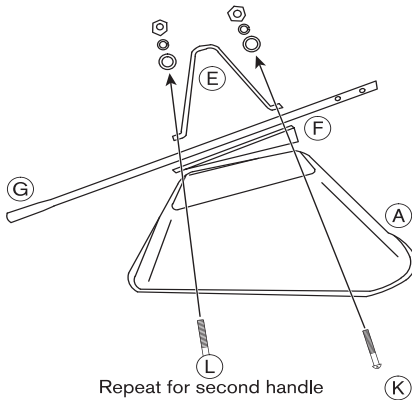

Repeat for second handle

**STEP/ ÉTAPE 2**

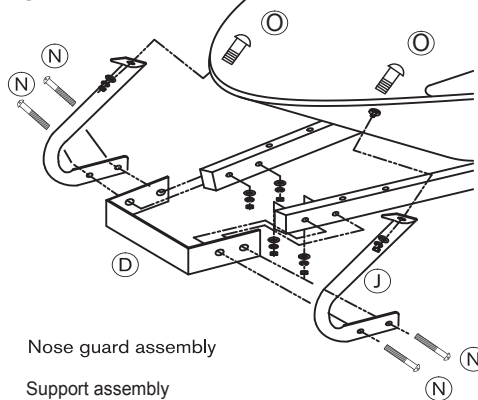

Nose guard assembly  
Support assembly

**STEP/ ÉTAPE 3**

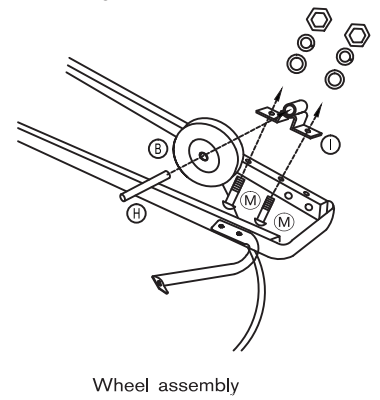

Wheel assembly

**STEP/ ÉTAPE 4**

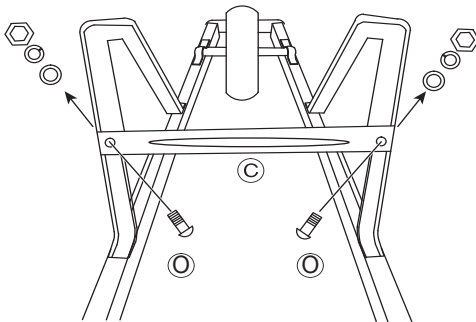

Leg brace assembly

**STEP/ ÉTAPE 5**

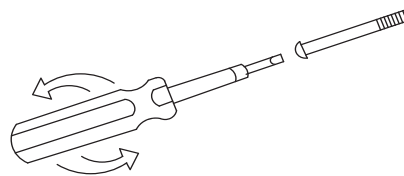

Align parts and tighten all bolts securely for safety.

Aligner les pièces et bien serrer tous les boulons pour plus de sécurité

**CARE INSTRUCTIONS:**

After use, clean with a wet, soft cloth or sponge. Rinse thoroughly. When not in use, store in a dry or sheltered location. If stored outdoors, place, upright, upside down or sideways to ensure water does not collect in the tray to avoid rust formation.

**INSTRUCTIONS D'ENTRETIEN:**

Après utilisation, nettoyer avec un chiffon doux humide ou une éponge. Rincez bien. Lorsqu'il n'est pas utilisé, conserver dans un endroit sec ou emplacement abrité. Si vous l'entrezposez à l'extérieur, placez-le debout, à l'envers ou de côté s'assurer que l'eau ne s'accumule pas dans le plateau pour éviter la formation de rouille.